

User Guide

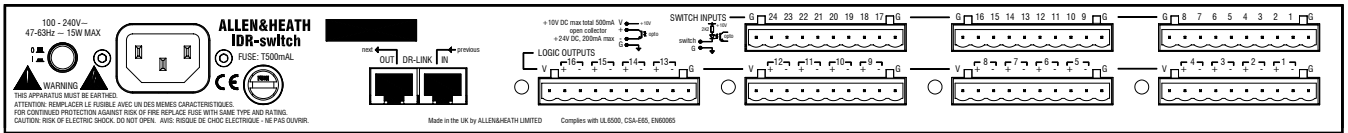

The **iDR-switch** is an add-on control expander for the **iDR-8** audio mix processor. It provides an additional 24 switch closure control inputs and 16 logic control outputs in a 1U high rack or desk mount case. Up to three units can be connected providing up to 72 additional switch and 48 additional logic controls. These can be custom wired by the installer to allow external equipment to control pre-determined mixer functions, or the mixer to control external equipment. Typical applications include room wall plates for local volume control and source selection, patch recall, logic control, automatic control of room dividers, projection screens, media players, lamps and other equipment.

The inputs and outputs are opto-isolated to avoid problems with equipment interaction. Grounding the switch inputs using simple contact closures triggers the programmed function. The logic outputs are open collector and can be wired to use the internal reference voltage or an external power supply. These typically drive LED indicators, filament bulbs, relays and circuit logic. Wiring the interface should be carried out by competent installation personnel. The switch and output functions are easily programmed using the iDR System Manager software.

The **iDR-8** communicates with the **iDR-switch** via the DR-Link port. This uses the proprietary Allen & Heath DR-Link protocol. A standard 2 metre CAT5 STP cable is provided. However, you can use a cable up to 300 metres long letting you position the unit closer to the local switch wiring. A pass through connection lets you network up to three units by daisy chaining them.

Plan the system Before starting make sure you have planned how the system is to work. Allocate the switch inputs and logic outputs and keep a log of their intended function. Use the iDR System Manager software to configure the system. Simulation windows are provided for you to try out your settings without access to the units themselves. Refer to the Help file that comes with the iDR System Manager software for details on how to assign the switch inputs and logic outputs.

CE This product complies with the European Electromagnetic Compatibility directives 89/336/EEC & 92/31/EEC and the European Low Voltage Directives 73/23/EEC & 93/68/EEC.

NOTE: Do not remove the cover of the **iDR-switch** unit. There are no user serviceable parts inside. Any changes or modifications to the equipment not approved by Allen & Heath could void the compliance of the equipment and therefore the users authority to operate it.

iDR-switch User Guide AP5141 Issue 2

Copyright © 2002 Allen & Heath Limited. All rights reserved

Whilst we believe the information in this guide to be reliable we do not assume responsibility for inaccuracies. We also reserve the right to make changes in the interest of further product development.

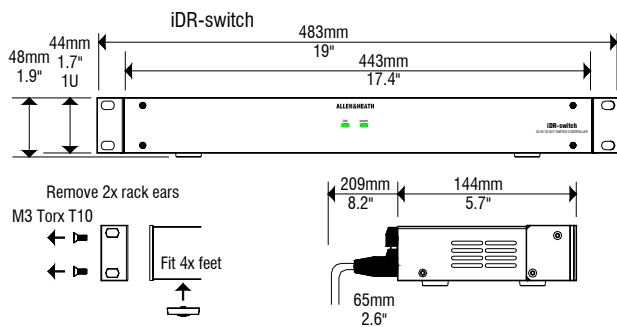

The **iDR-switch** can be rack mounted or free standing. There are no user controls on the front panel. Allow a minimum of 65mm clearance behind the unit for the connectors and cables. Ensure adequate ventilation to the side of and behind the unit.

It is shipped with its rack ears fitted and its feet removed ready to be mounted in a standard 19" equipment rack. 1U rack space is required. For desk mount operation remove the two rack ears using a Torx (star head) T10 screwdriver. Fit the four plastic feet provided by pressing them into the underside.

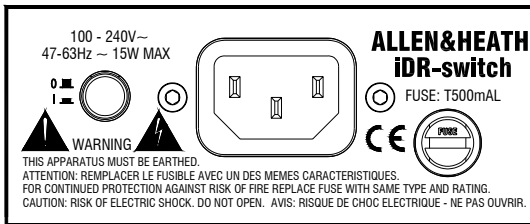

▲ Make sure you have read the Safety Instructions Sheet AP3345 which comes with the unit. Check that your local mains supply is compatible with that printed on the rear panel of the unit. Ensure that the correct mains lead with moulded plug and IEC connector has been supplied. For your own safety and optimum performance make sure the system is correctly grounded.



Turning the expander on or off Turn the unit on by pressing the rear panel power ON/OFF switch. The power LED lights up. The link LED lights if the DR-Link connection is established with the **iDR-8**.

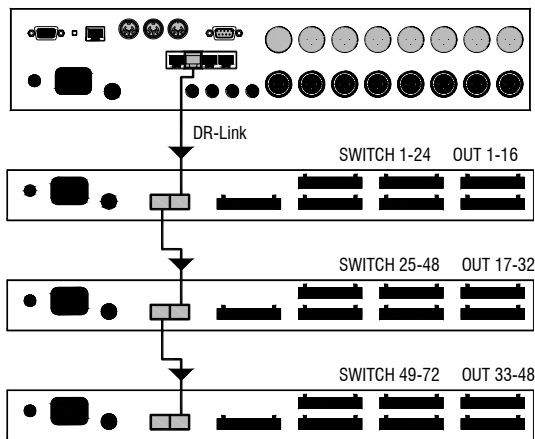

Connecting to the iDR-8 The **iDR-8** communicates with the **iDR-switch** using the DR-Link port. This serial connection can be daisy chained through the 3 switch units as shown, and then on to the **iDR-in** and **iDR-out** expanders if fitted. Make sure you plug the DR-Link IN and OUT sockets correctly. Use CAT5 STP cables with RJ45 connectors. Do not use UTP cable. A standard 2 metre cable is provided with each unit. You can use cables up to 300 metres long between units for remote positioning. Ensure a good mains supply and solid grounding to each unit.

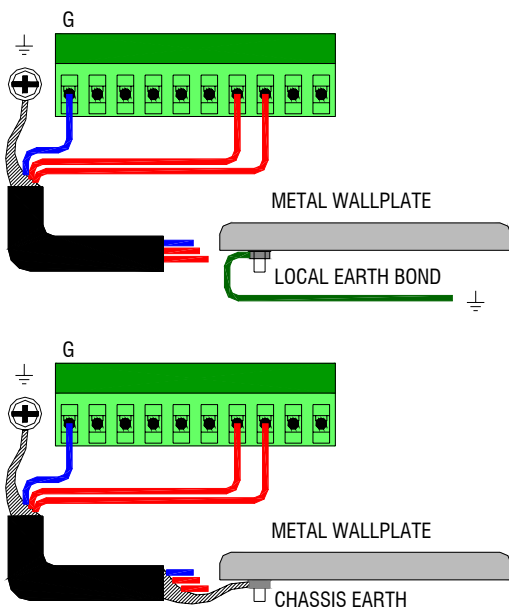
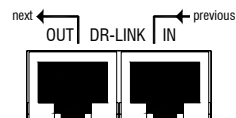

Connectors and grounding Pluggable Phoenix type screw terminal connectors are used for connecting the external switches and logic to the **iDR-switch**. Mating plugs are provided with the unit. Make sure the wire ends are carefully stripped and inserted into the terminals. Tighten the screws using the correct slotted screwdriver. To ensure interference-free operation use shielded cable. Connect the shields to the chassis ground screw terminals provided next to each connector. Fit the screws with the shake proof washers provided.

▲ For operator safety make sure that wall plates and other control surfaces made from metal are correctly bonded to ground (earth).

Strap the metal plate to the local ground at the wall box. For ground isolation between the wall plate and equipment rack connect the cable shield at the **iDR-switch** end only.

If a local ground is not available then use the cable shield to connect the plate to the chassis of the **iDR-switch** unit as shown. This is not necessary if the wall plate is made of non-conductive material such as plastic which insulates it from the operator.

Important Note: The **iDR-switch** provides contact closure switch inputs and open-collector logic outputs. How these are wired to external equipment is the responsibility of the installer. Specification details are provided here for the **iDR-switch** inputs and outputs. It is important that the installer is suitably qualified and familiar with external control circuits to be able to work within the capabilities of the unit. Allen & Heath do not assume responsibility for any damage done to the unit due to incorrect or faulty connection to external equipment.

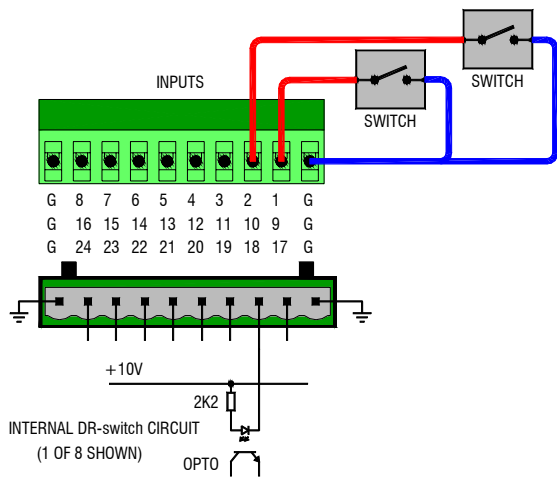

Using the switch closure inputs The input is opto-coupled to isolate the **iDR-switch** from the connected equipment. It is switched by linking its connector pin to the ground ('G') pin. Use a contact closure such as a momentary press switch to do this.

The input pin is fed from the internal +10V reference supply through a 2k2 ohm resistor. Around 5mA maximum current flows when connected to ground. Combined switch and cable resistance should not exceed 1k ohm for the switch to activate.

Each 10way connector provides 8 switch inputs. Either pin 1 or pin 10 'G' may be used as the common switch ground. One cable can feed this ground to a bank of switches. Two are shown in the diagram here. Do not use the chassis ground screw which is for cable shielding and safety earthing only.

For reliable operation we recommend the use of heavy duty sealed switches.

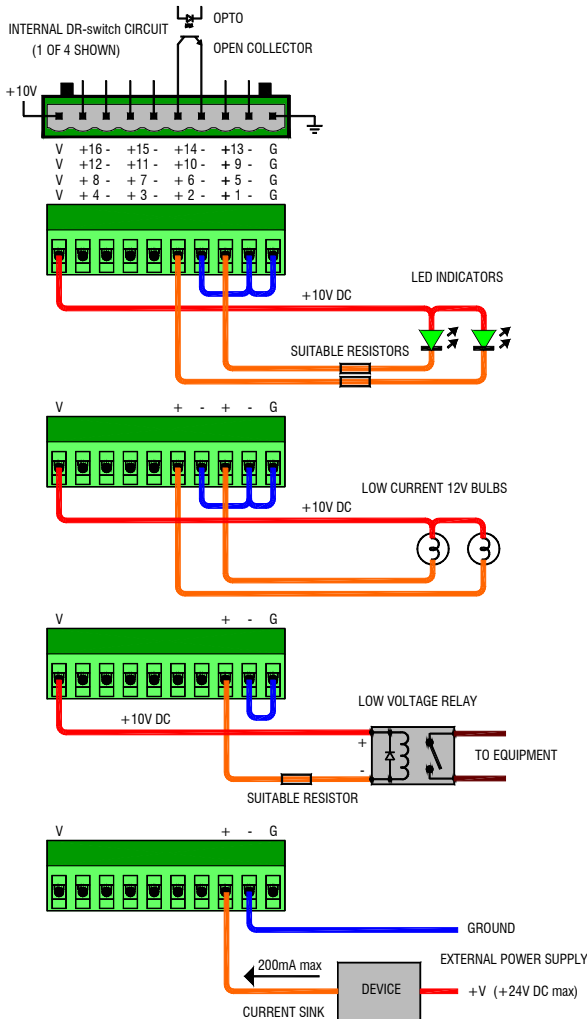

Using the logic outputs Each output is opto-coupled to isolate the **iDR-switch** from the connected equipment. It provides an open collector output with floating collector (+ pin) and emitter (-pin).

Each 10way connector provides 4 open collector pairs as well as an internal +10V DC supply and ground pins. Do not use the chassis ground screw which is for cable shielding and safety grounding only.

The output may be used in many ways to satisfy a wide range of interfacing applications. It is important that the installer has a good working knowledge of open collector and interfacing circuits. Incorrect application may result in damage to these outputs.

The internal +10V supply may be used as the power source for low current applications such as turning on LEDs, lamps and small relays. One cable can feed the common supply or ground to a bank of outputs.

Maximum current drawn from the +10V supply for all outputs combined must not exceed 500mA. Care must be taken in component choice to ensure each operates within its specified capability.

For higher current or voltage applications an external DC power supply may be used. This also provides total isolation between the **iDR-switch** and external equipment.

Maximum external supply voltage must not exceed +24V DC. Maximum current sink through any open collector output must not exceed 200mA.

A few examples are shown in the diagram here. For further advice contact Allen & Heath technical support.

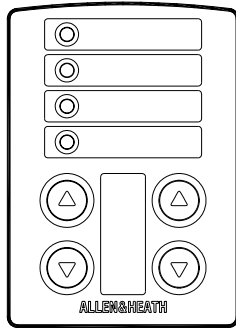

Remote controllers The iDR-switch is designed to be used with a wide range of remote control devices including custom wall plates and operator panels. Check out the Allen & Heath range of **PL** wall plates and remote controllers. This range is continually developing and it is likely that some may be suitable for your application.

At the time of print of this user guide the **PL-2** wall plate is available for use with the **iDR-switch**. It has 4 switches and 4 3-colour LEDs which can be hard wired to the unit. It can be fitted into a UK or US standard single wall box. For further details visit the Allen & Heath web site.

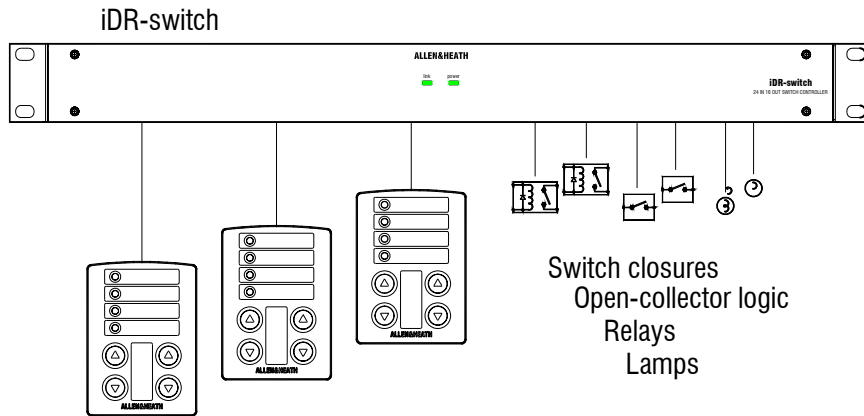

Connectors:

Pluggable Phoenix 10way terminal
Mating screw terminal plugs provided

Switch Inputs:

24x switch closure inputs
Opto-isolated via 2k2 from +10V
Switch closure connects pin to ground (5mA)
Switch cable resistance up to 1k ohm

Logic Outputs:

16x logic outputs
Opto-isolated open-collector
Floating collector (+) and emitter (-) pins
Internal 10V DC source (500mA total max)
External DC source (+24V 200mA each max)

Communication:

DR-link serial port using RJ45 connectors
Uses Allen & Heath DR-link protocol
2m CAT5 STP cable supplied, max 300m
Daisy chain up to 3 units

Configuration:

Configure with iDR System Manager operating software
Separately configure switches and output
Latched, press, release, time of day action

Power Supply:

Universal mains input 100-240V.AC
Independent 10V supply for connections
500mA total available

Dimensions:

Rack 483 x 144 x 44 mm (1U)
19" x 5.7" x 1.7"
Desk 443 x 144 x 48 mm
17.4" x 5.7" x 1.9"
Allow 75mm 3" for connectors
Weight 2.2kg 5lbs

